

**F-SERIES WHEEL LOADERS**  
**721F | 821F | 921F**

**CASE**  
CONSTRUCTION



**TIER 2**  
EU STAGE II

**FASTER,**  
**FUEL EFFICIENT**

[www.casece.com](http://www.casece.com)  
**EXPERTS FOR THE REAL WORLD**  
**SINCE 1842**

# **FASTER, FUEL EFFICIENT**



## **BE READY FOR THE BEST:**

- Advanced Engine Technology
- High Efficiency Transmission
- High Productivity Differential and Axles
- Low Maintenance Cooling Design
- Premium Ergonomics

## **10% LOWER FUEL CONSUMPTION**

The high combustion temperature results in optimum engine performance. The second generation common rail engine ensures better engine control at all rpm. The multiple injection technology delivers optimum combustion control.

## **OUTSTANDING FLAT TORQUE**

The second generation common rail engine ensures better engine control at all rpm and the 100% fresh air input further improves engine output. The multiple injection technology ensures optimum combustion control, while the 1600 bar injection delivers best-in-class torque performance.

## **LOWER MAINTENANCE COSTS**

The combustion chamber and high pressure injection are optimized to reduce oil dilution. The engine only breathes fresh air, so there is no oil contamination. It also has better fuel compatibility because there is no exhaust gas recirculation.





## **10% ADDITIONAL FUEL EFFICIENCY AND LESS MAINTENANCE**

Proshift delivers 10% more fuel savings than older type 4-speed transmissions and lengthens the life of transmission oil from 1000 to 1500 hours, resulting in maintenance intervals being 50% longer. The premium performance of Proshift results in a superior resale value for the 721F, 821F and 921F, as no equivalent model offers such a superior performance.

## **MAXIMUM PRODUCTIVITY**

Proshift delivers faster acceleration and, with the slightly shorter 2nd gear, more pushing power.

## **SUPERIOR COMFORT**

Proshift results in a remarkably comfortable ride, with exceptionally smooth gear change and, when braking, with engine de-rating.

# **HIGH PRODUCTIVITY**

## **DIFFERENTIAL AND AXLES**



### **NEW HEAVY-DUTY AXLES**

The new heavy-duty axles are tougher, bigger and easier to service with the 3-piece housing design. Wet multiple disc brakes made of resistant sinter bronze are located in each wheel hub.

### **FRONT DIFFERENTIAL WITH 100% AUTO-LOCK (921F)**

With 100% Auto-lock, 100% of the available torque goes to the wheel with adherence.

There is no slippage between the wheels and no friction in the differential.

The Auto-lock is activated automatically when a front wheel is about to slip, or you can easily do it manually with your left foot.



721F and 821F are standard with limited slip differentials.







# LOW MAINTENANCE COOLING DESIGN



## BETTER WEIGHT DISTRIBUTION WITH THE REAR MOUNTED ENGINE

### MID-MOUNT COOLING SYSTEM

This unique design, with the five radiators mounted to form a cube instead of overlapping, ensures that each radiator receives fresh air and that clean air enters from the sides and the top, maintaining constant fluid temperatures. The high efficiency of the cooling system lengthens the life of the coolant to 1500 hours. The standard reversible fan can be activated from the cab and is very effective thanks to the mid-mount cooling system.

The engine is mounted at the rear of the machine, therefore minimizes the need for an additional counterweight. This, together with the lower fan speed (just 1200 rpm), results in lower noise and vibration levels in the cab.

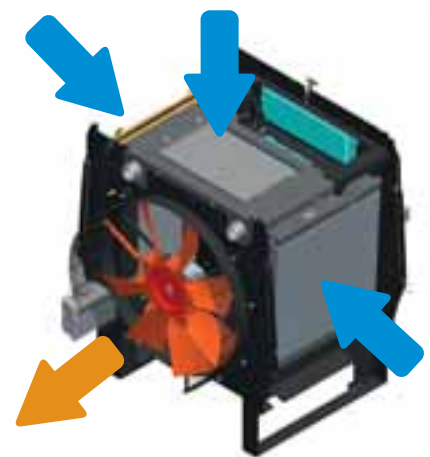

### DESIGNED FOR DUSTY ENVIRONMENT

The cooling system is mounted behind the cab, far from the rear of the machine and from the ground - away from the dust.



## LESS MAINTENANCE

The radiators are easy to clean with the reversible fan, which is activated from the cab. The cube design of the cooling system results in more effective cleaning of the radiators, and additional cleaning can be easily done manually, with separate access to each radiator. The efficient cube design also results in a longer life for the cooling fluid, which lasts 500 hours more, so that change intervals are 1500 hours.

## INCREASED RELIABILITY

The constant temperature of the fluid maximises its cooling performance and protects the axles, resulting in greater reliability. This is further enhanced by the easy maintenance and longer service intervals. The better weight distribution means that a smaller counterweight or dead weight is needed, which reduces stress on the axles and the brakes.

## UPPER CLASS BUCKET PAYLOAD

Don't be surprised to notice our wheel loader has the same payload as a competitive model of the upper class of weight: this happens because the rear engine position allows to reduce significantly the amount of dead weight in the machine.



# PREMIUM ERGONOMICS



## PROTECTED CAB

Our reinforced cab guarantees protection against roll over (ROPS) and falling objects (FOPS).

## LOW OPERATOR VIBRATIONS

Engine noise and vibrations are reduced by 3-step injection: pre-, main- and post-injection. To further increase the operator comfort the rear mounted engine is distant from the cab and an air suspension seat is standard.



## ALL CONTROLS AT YOUR FINGERTIPS

## OUTSTANDING ALL-ROUND VISIBILITY

You'll feel more confident and work faster with the great all-round visibility provided by the very low shape of the curved rear hood and the ample glazed surfaces.

17 air vents ensure your comfort and prevent the windshields from steaming up.







# PREMIUM ERGONOMICS



## HYDRAULIC FUNCTIONS THAT ADD TO YOUR COMFORT

To maximise your focus on the job and reduce your stress levels, you can activate the following functions from the ergonomically positioned control panel under your right hand:

- **Auto-shift:** ensures the machine always operates in the most suitable gear according to speed, kick down and engine braking
- **Reverse button on the joystick:** activates front, neutral or reverse
- **Return to dig:** brings back the bucket in the right position for loading again
- **Return to travel:** lowers the boom to carry position, which can be adjusted
- **Auto-lift:** lifts the boom to the max height you have set
- **Auto-Ride Control:** reduces loader arm bounce during travel, maintaining maximum material retention. It activates from 8 km/h
- **Auto-diff lock:** The 100% differential lock can be activated manually with your left foot or automatically for greater focus on the job
- **Auxiliary circuit lever:** For hydraulic attachments such as high tip bucket, you can order the optional auxiliary circuit controlled by a lever next to the joystick for your ease of use.





## LEVERS OR JOYSTICK LOADER CONTROL

Depending on your habits you may prefer the optional 2-lever control to the standard joystick control. The optional 3rd lever controls the attachment auxiliary circuit. It can also be retrofitted as a kit.



## JOYSTICK STEERING

Long days of repetitive cycles go faster with joystick steering (optional) because your sitting position is better. The steering wheel is maintained for a better handling. You will appreciate it during transfers on uneven terrains, on a descending slope and in case of emergency

# FAST AND EASY MAINTENANCE



The layout of the components under the hood is optimized and results in easier maintenance.



Hood opening and battery on/off switches. In case of flat battery, hood opening can be done externally with remote jump start



Grouped drains

## ONE-PIECE ELECTRIC HOOD

The positioning of the engine at the rear and the easy-to-open electric hood ensure fast access to the service points. Jumper cables are available as standard for jump starting the engine if the battery is low.

## GROUND LEVEL MAINTENANCE DESIGN

Don't be surprised if you don't see any safety handrails around the hood or steps behind the rear wheels, all service points are easily accessible at ground level. You can do a fast visual check of the hydraulic and transmission oil levels. The three drains are grouped together on the left side, below the hood and battery switches, so that fluids are easy and quick to replace.

## LESS MAINTENANCE, MORE UPTIME

You can maximise the working time with these wheel loaders, with the long service intervals of 1500 hours for the transmission oil and filter, the axle oil and filter, and the coolant. The positioning of the cooling system behind the cab means that it needs less cleaning, and the cooling cube design enables you to clean very efficiently with the reversible fan as well as manually.

Both pumps and engine distributions rely on one belt only for faster maintenance.

## GREATER SAFETY

All the main service points are easily accessible from the ground, so you can carry out your daily maintenance safely and efficiently.







## THE CASE DEALER: YOUR PROFESSIONAL PARTNER

Your success starts with world-class Case machinery and attachments.

Your Case dealer will help you work smarter and faster by selecting equipment that delivers performance and operator comfort.

Your dealer has the knowledge and experience necessary to help you choose the right attachments so you can...

- **Work faster and extend equipment life.**
- **Increase machine utilization.**
- **Increase your capabilities.**

Let your Case dealer service your machine on the jobsite.

You'll be back on the job faster.

Advantages include...

- **Responsive job site service to keep your equipment running.**
- **Increase machine uptime.**
- **Certified service staff and improved parts availability.**





## **PARTS**

When you're looking for superior parts options to maximize the performance and lower the operating costs of your Case machinery, turn to CNH Industrial Genuine Parts to keep you equipped for success.

CNH Industrial Genuine Parts fit better, install faster and last longer and in an industry where "high impact" and "heavy lifting" are the norm, the smallest mechanical differences can lead to big problems.

CNH Industrial Genuine Parts from Case are manufactured from superior materials and specifically designed for Case construction equipment to continually and reliably withstand the punishment of everyday construction. So steer clear of mechanical problems and future breakdowns, by choosing CNH Industrial Genuine Parts from Case. They're the only parts that are field-tested and proven to keep your Case equipment performing its best.

## **SERVICE. RELY ON CASE TO DELIVER FOR YOU**

Your commitment to your operation is evident every day, but that doesn't minimize the enormous pressure you face to reduce operating costs and improve productivity. So when you're on the job, make sure you have top-notch service and support of Case behind you every step of the way.

With our factory trained technicians, you can ensure that top-notch service professionals are working on your maintenance needs, so you can focus on your business and the big job challenges ahead, not on the tasks of servicing your equipment.

With your Case Service, you get more than mere oil changes. A Case Service ensures your Case equipment receives a thorough service that meets all requirements of its service schedules and properly maintains it for the day-in, day-out punishment of construction work.

Don't give another thought to time-consuming maintenance tasks. Simply rest easy and make certain that your service needs are taken care of by a Case factory trained technician.

When the unexpected occurs, you need to know your equipment is protected.  
At Case Construction we understand the importance of your machinery being in good working order when it counts.

ProCover is designed to help keep your equipment working well beyond the manufacturer's base warranty period while taking away the concerns of the cost and inconvenience of mechanical failure.

## WHAT ARE THE ADVANTAGES OF PROCOVER?

### PEACE OF MIND

Provides protection beyond the Manufacturer's Base Warranty Period.

### FLEXIBLE OPTIONS

Plans can be customised to meet individual needs.

### DEPENDABLE SERVICE

Eligible repairs completed by an authorised Case Construction Dealership and their trained service technician's using genuine OEM parts & lubricants.

### TRANSFERABLE PROTECTION

New Equipment Plans may be transferred to a new owner at no charge

## COVERAGE

- **STANDARD PROTECTION PLAN**     **3 Years / 5000 Hours**  
Additional years/hours can be purchased.  
Please contact your local Case Construction dealer for further information.

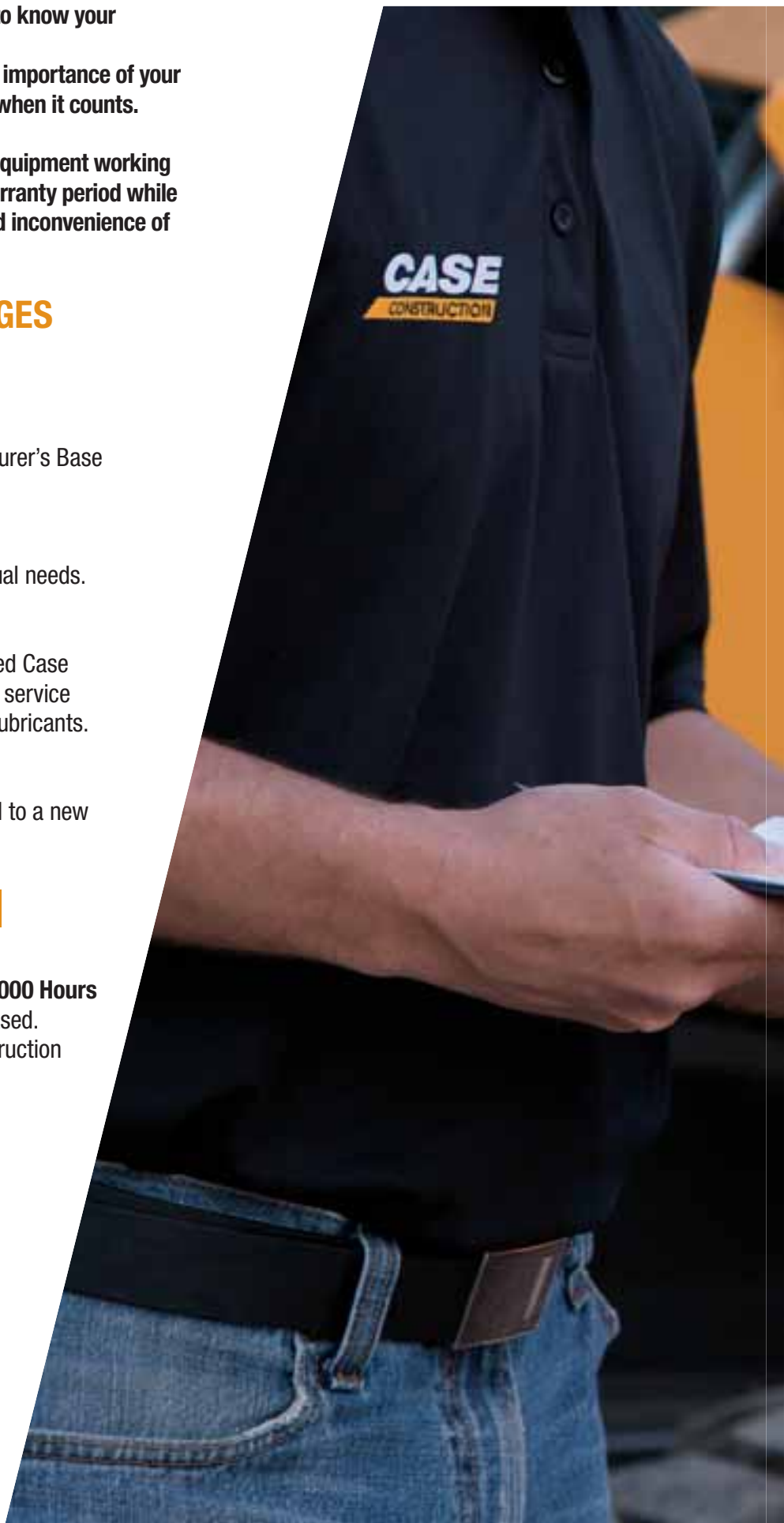



# STANDARD PROCOVER PLUS PROTECTION PLAN

## CONSTRUCTION EQUIPMENT MASTER PARTS SCHEDULE

This plan provides coverage for the components listed below when a failure occurs due to a defect in material or workmanship, and may provide coverage for additional components not listed when the damage is caused by or resulting from a covered failure of a listed component.

### PREMIER COMPONENTS COVERED

ENGINE AND ALL INTERNAL LUBRICATED COMPONENTS WITHIN	TRANSMISSIONS/AXLES/HYDROSTATICS	ELECTRICAL	HYDRAULICS
Accessory Gears	Axle Housing	Alternator	Accumulator And Related Relief Valve
Air Intake Hose	Axle Shaft	Gauges	Brake Accumulator
Camshaft	Clutch Discs (Wet Only)	Horn	Brake Pressure Sensor
Camshaft Bearings	Clutch Plates (Wet Only)	Indicators	Brake Pump, Brake Valve
Camshaft Drive Gear	Control Rods	Instruments	Differential Lock Valve
Catalytic Converter	Counter Shaft Clutch	Electronic Joysticks	Fan Pumps And Motors
Charge Air Cooler	Differential Housing	Electric Motors	Hydraulic Cylinders
Cold Start Enrichment Systems	Differential Pinion Gear / Ring Gear	Factory Installed Telematics	Hydraulic Hoses and Piping
Connecting Rods & Bearings	Drive Axle Hub	Sensors	Hydraulic Motors
Crankshaft Bearings & Gear	Drive Shaft Support Bearing	Solenoid Valves	Hydraulic Oil Coolers
Crankshaft Including Front And Rear Crankshaft Seals	Drive Shaft with Universal Joints	Starter And Starter Solenoid	Hydraulic Pumps
Cylinder Heads/ Head Gaskets	Electronic Transmission Controller and Valve	Switches	Hydraulic Reservoir
Cylinder Liners	Enclosed Oil Immersed Chains and Sprockets	Traction Control System	Hydraulic Valves
Diesel Exhaust Fluid Tank and Dispensing System	External Oil Lines	Voltage Regulator	Internal O-Rings and Bonded Washers
Diesel Particulate Filter	Filler Tubes (Transmission)	Wiring Harnesses	Pilot Control
EGR System Manifold	Final Drive Pinion	Wiring Harnesses Exclusions	Pressure Reducing Valves
Electronic Engine Control Module	Final Drive Planetary Gears	Rubbing, Chafing, Loose Or Corroded Connections	Unloading Valves
Engine Block	Front Wheel Drive Sensors	<b>FACTORY INSTALLED HEAT AND AIR CONDITIONING</b>	<b>STRUCTURAL</b>
Engine Mounts And Supports	Hydraulic Drive / Travel Motor	Accumulator	Backhoe Booms
Engine Oil Cooler	Hydraulic Drive Pump	Clutch	Backhoe/Excavator Dipper Sticks
Engine Speed Controls, Linkages, and Cables	Hydraulic Transmission-Control Valve	Compressor	C Frame
Exhaust Manifold and Muffler	Hydrostatic Motor	Condenser	Car Body
Fan And Fan Drive	Hydrostatic Transmission Charge Pump	Dryer	Chassis
Filter Mount	Hydrostatic Transmission Pump	Evaporator	Circle Frame
Flywheel, Ring Gear	Hydrostatic/Hydraulic Pump Drives	Expansion Valve	Engine Frame
Front And Rear Engine Covers And Seals	Internal Lubricated Clutch Housings	Heater Core	Equipment Frame
Front Damper	Internal Transmission Control Linkage	Hoses	Excavator Booms
Fuel Lines	Internal Wet Service Brakes	Pulley	Falling Object Protection Structure (FOPS)
Fuel Tank	MFWD Axle/Differential Assembly including Driveshaft and U Joint	Seals & Gaskets	Forklift Masts
Fuel Transfer Pump & Gasket	Planetary Gear Carrier	Temperature Control Programmers and Valves	Inner and Outer Dipper Arms of the Extendable Boom (Backhoe Loader)
Injection Pump	Pneumatic Valves	<b>OPERATOR AREA</b>	Main Frame
Injectors	Rotary Hydraulic Manifold	Covers and Panels	Rollover Protection Structure (ROPS)
Intake and Exhaust Manifold And Gaskets	Splitter Drive/Drop Box	Exterior/Interior Door/Panel Latches, Hinges & Struts	Swing Frame
Oil Filler Tube	Steering Clutches (Wet)	Exterior/Interior Moldings	Swing Tower Castings (Backhoe Loader)
Oil Lines	Swing Motor And Swing Gear Box	Knobs for Switches and Handles	Track Frame
Oil Pan And Gasket	Torque Converter	Mirrors	Wheel Loader/Skid steer Loader Arms
Oil Pump	Torque Converter Pump	Seat Frame & Suspension	
Pistons & Rings	Transfer Drive		
Pre-Cleaner/Air Cleaner Housing	Transmission Case		
Pressure/Temperature Sensors & Sending Units	Transmission Gears, Bearings, & Shafts		
Pulleys	Transmission Pump		
Radiator	Travel & Swing Sections (only) Of Main Control Valve		
Rocker Arm Assembly	Travel Control Valve		
Selective Catalytic Reduction System	Turntable Bearing		
Thermostats	Undercarriage Roller And Idler Seals And Bearings		
Timing Gears	Undercarriage Tensioners		
Turbocharger And Gasket	UNDERCARRIAGE EXCLUSIONS:		
Valve Cover And Gasket	Sprocket, Tracks, Pads, Bolts, Chains, Or Any Failure Due To Wear, Or Breakage Caused By Wear		
Water Piping			
Water Pumps			

# THE DNA OF YOUR 721F

## PRODUCTIVITY (50-meter distance cycle)

Considering: density: 1,8 t/m<sup>3</sup>, fill factor: 100%, 52 cycles/hour and each hour includes a 5-minute break \_\_\_\_\_ 140 m<sup>3</sup>/h or 280 t/h  
52 loading cycles/h with standard bucket 2.7 m<sup>3</sup> or 5.4 ton

## ENGINE TIER 2

Compliant with Tier 2 (EU stage II regulations)  
FPT turbocharged engine F4HFA613B with:

- 100% fresh air combustion
- Air to Air intercooler
- Second generation common rail (1.600 bar)
- Multiple injections similar to multi-jet automotive technology to achieve best in class load response, max torque and power with the minimum fuel consumption.

6 cylinders -6,7 liters

Max power SAE J1995 \_\_\_\_\_ 145 kW / 195 hp @1800 rpm

Maximum torque SAE J1349 \_\_\_\_\_ 950 Nm @1300 rpm

## TRANSMISSION

All-wheel drive with planetary axles

Kick-down function

4-speed torque converter

4-speed auto Powershift switchable to manual shifting

ZF, switchable to manual shifting

forward speeds \_\_\_\_\_ 8-13-25-37 Km/h

reverse speeds \_\_\_\_\_ 8-13-26 Km/h

Adjustable transmission declutch

## AXLES AND DIFFERENTIAL

Limited slip differential front and rear \_\_\_\_\_ when one wheel slips 73% of the available axle torque is guaranteed on the other wheel

Front \_\_\_\_\_ Heavy Duty axle +(ZF type MT-L3085-II)

Rear \_\_\_\_\_ standard axle (ZF type MT-L3075-II)

Rear axle total oscillation \_\_\_\_\_ 24°

## TYRES

Tyres \_\_\_\_\_ 20.5R25

## BRAKES

Service brake \_\_\_\_\_ Maintenance free, self-adjusting wet 4-wheel disc brakes  
Area \_\_\_\_\_ 0.39 m<sup>2</sup>/hub

Parking brake \_\_\_\_\_ Disc brake on transmission activated from the cab cluster

Area \_\_\_\_\_ 82 cm<sup>2</sup>

## HYDRAULIC

Valves \_\_\_\_\_ Rexroth Closed-center, Load sensing hydraulic system.  
Main valve with 3 sections

Steering \_\_\_\_\_ The steering orbital is hydraulically actuated with priority valve  
Type of pump \_\_\_\_\_ Tandem Variable displacement pump  
(206 l/min @2000 rpm)

Automatic hydraulic functions

- Bucket Return-to-dig
- Boom Return-to-travel
- Auto.lift (to adjustable height)

Control type \_\_\_\_\_ Pilot control with single joystick or two levers

## CAPACITIES

Fuel tank \_\_\_\_\_ 246 usable litres

Cooling system \_\_\_\_\_ 28 litres

Engine oil \_\_\_\_\_ 15 litres

Hydraulic oil \_\_\_\_\_ Tank: 91 litres, total system: 180 litres

Transmission oil \_\_\_\_\_ 34 litres

## CAB AND CONTROLS

For your safety the cab complies to:

protection against falling objects (FOPS) \_\_\_\_\_ ISO EN3449

protection against roll over (ROPS) \_\_\_\_\_ ISO EN13510

## NOISE AND VIBRATION

Driving noise in dB (A) 82 to SAE J88 @ 15 meters

Interior noise \_\_\_\_\_ 72 LpA as per ISO6395/6396/3744

Exterior noise \_\_\_\_\_ 71 dB(A) at 15 meters as per SAE J88 SEP80  
103 LwA according to ISO6395/6396/3744

Switchable reverse gear alarm

Vibrations \_\_\_\_\_ air-cushioned seat MSG 95A/732  
average 1.4m/s<sup>2</sup> as per ISO/TR 25398:2006

## ELECTRICAL SYSTEM

24V. Batteries 2 x 12V.

Alternator \_\_\_\_\_ 65A



# SPECIFICATIONS

## GENERAL DIMENSIONS

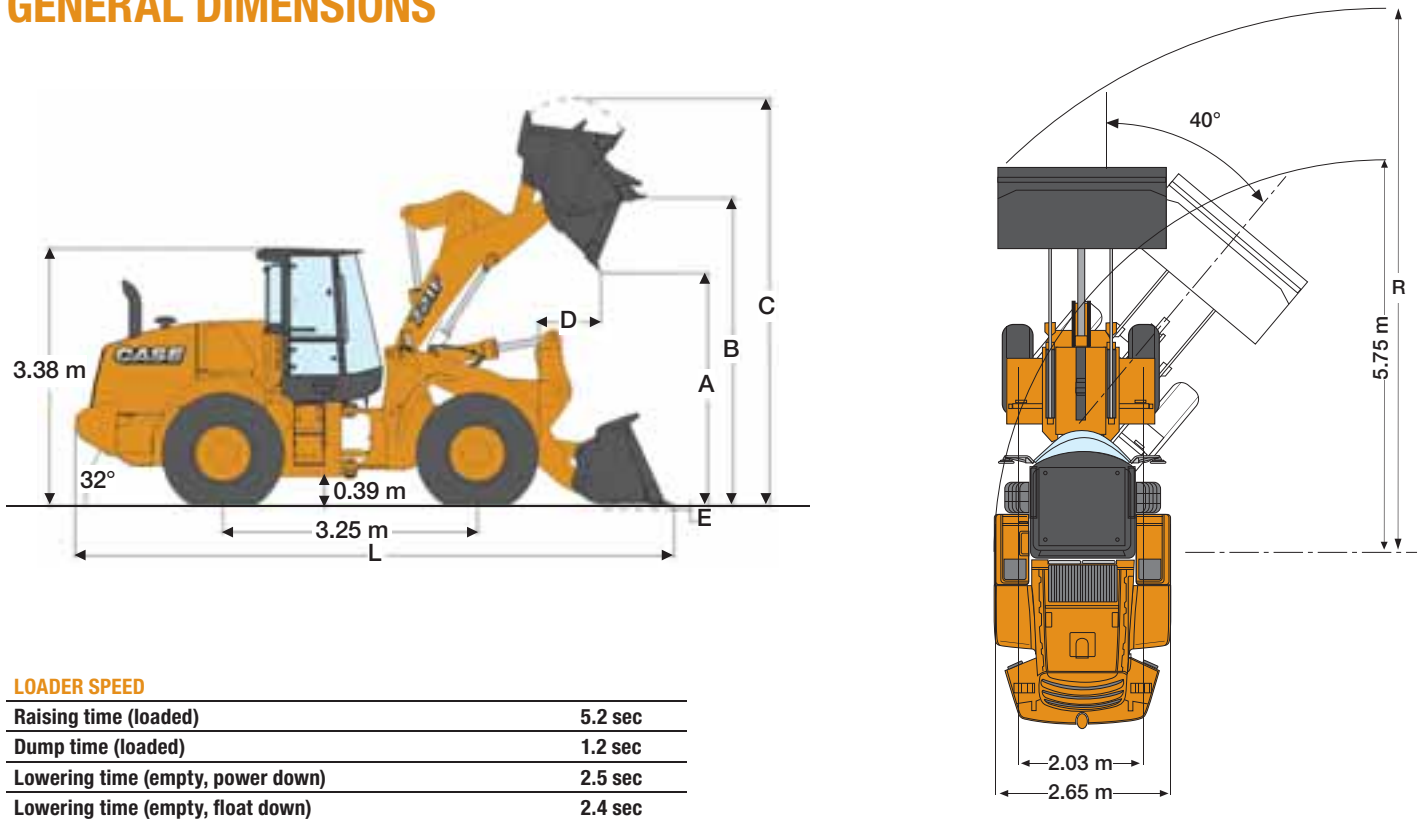

### LOADER SPEED

Raising time (loaded)	5.2 sec
Dump time (loaded)	1.2 sec
Lowering time (empty, power down)	2.5 sec
Lowering time (empty, float down)	2.4 sec

721F		Z-BAR		XT BUCKETS (PARALLEL LIFT) w/QC	
		edge	teeth	edge	teeth
	Bucket with bolt on:				
	Bucket volume (heaped)	m <sup>3</sup>	2.7	2.5	2.4
	Bucket Payload	kg	5199	5310	4924
	Maximum material density	ton/m <sup>3</sup>	1.8	2.0	2.1
	Bucket outside width	m	2.70	2.73	2.47
	Bucket weight	kg	1280	1225	1627
	Tipping load - straight	kg	11896	12142	11280
	Tipping load - Articulated at 40°	kg	10397	10620	9847
	Breakout force	kg	13486	15344	12016
	Lift capacity from ground	kg	13307	13550	13096
A	Dump height at 45° at full height	m	2.89	2.83	2.77
B	Hinge pin height	m	3.98	3.98	4.16
C	Overall height	m	5.17	5.17	5.67
D	Bucket reach at full height	m	1.17	1.24	1.27
E	Dig depth	mm	74	78	58°
L	Overall length with bucket on the ground	m	7.65	7.76	8.12
	Dump angle at full height	°	55°	55°	55°

Note: bucket specification can slightly differ according to plant source. More bucket choice is available, please contact your local dealer.

# THE DNA OF YOUR 821F

## PRODUCTIVITY (50-meter distance cycle)

Considering: density: 1,8 t/m<sup>3</sup>, fill factor: 100%, 52 cycles/hour and each hour includes a 5-minute break \_\_\_\_\_ 160 m<sup>3</sup>/h or 320 t/h  
52 loading cycles/h with standard bucket 3.4 m<sup>3</sup> or 6.2 ton

## ENGINE TIER 2

Compliant with Tier 2 (EU stage II regulations)  
FPT turbocharged engine F4HFA613C with:

- 100% fresh air combustion
- Air to Air intercooler
- Common rail (1.600 bar)
- Multiple injections similar to multi-jet automotive technology to achieve best in class load response, max torque and power with the minimum fuel consumption.

6 cylinders - 6,7 liters

Max power SAE J1995 \_\_\_\_\_ 172kW / 230 hp @1800 rpm

7-12-23-37 Km/h

reverse speeds \_\_\_\_\_ 7-13-25 Km/h

Adjustable transmission declutch

## AXLES AND DIFFERENTIAL

Limited slip differential front and rear \_\_\_\_\_ when one wheel slips 73%  
of the available axle torque is guaranteed on the other wheel

Front \_\_\_\_\_ Heavy Duty axle +(ZF type MT-L3095-II)

Rear \_\_\_\_\_ standard axle (ZF type MT-L3085-II)

Rear axle total oscillation \_\_\_\_\_ 24°

## TYRES

Tyres \_\_\_\_\_ 23.5R25

## BRAKES

Service brake \_\_\_ Maintenance free, self-adjusting wet 4-wheel disc brakes

Area \_\_\_\_\_ 0.39 m<sup>2</sup>/hub

Parking brake \_\_\_ Disc brake on transmission activated from the cab cluster

Area \_\_\_\_\_ 82 cm<sup>2</sup>

## HYDRAULIC

Valves \_\_\_\_\_ Rexroth Closed-center, Load sensing hydraulic system.

Main valve with 3 sections

Steering \_\_\_ The steering orbitrol is hydraulically actuated with priority valve

Type of pump \_\_\_\_\_ Tandem Variable displacement pump

(240 l/min @2000 rpm)

Automatic hydraulic functions

- Bucket Return-to-dig
- Boom Return-to-travel
- Auto.lift (to adjustable height)

Control type \_\_\_\_\_ Pilot control with single joystick or two levers

## CAPACITIES

Fuel tank \_\_\_\_\_ 288 usable litres

Cooling system \_\_\_\_\_ 30 litres

Engine oil \_\_\_\_\_ 15 litres

Hydraulic oil \_\_\_\_\_ Tank: 91 litres, total system: 180 litres

Transmission oil \_\_\_\_\_ 34 litres

## CAB AND CONTROLS

For you safety the cab complies to:

protection against falling objects (FOPS) \_\_\_\_\_ ISO EN3449

protection against roll over (ROPS) \_\_\_\_\_ ISO EN13510

## NOISE AND VIBRATION

Driving noise in dB (A) 82 to SAE J88 @ 15 meters

Interior noise \_\_\_\_\_ 72 LpA as per ISO6395/6396/3744

Exterior noise \_\_\_\_\_ 71 dB(A) at 15 meters as per SAE J88 SEP80

103 LwA according to ISO6395/6396/3744

Switchable reverse gear alarm

Vibrations \_\_\_\_\_ air-cushioned seat MSG 95A/732

average 1.4m/s<sup>2</sup> as per ISO/TR 25398:2006

## ELECTRICAL SYSTEM

24V. Batteries 2 x 12V.

Alternator \_\_\_\_\_ 65A



# SPECIFICATIONS

## GENERAL DIMENSIONS

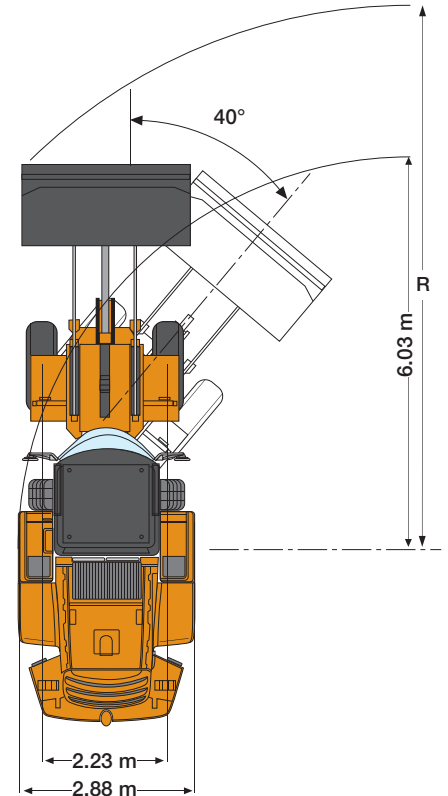
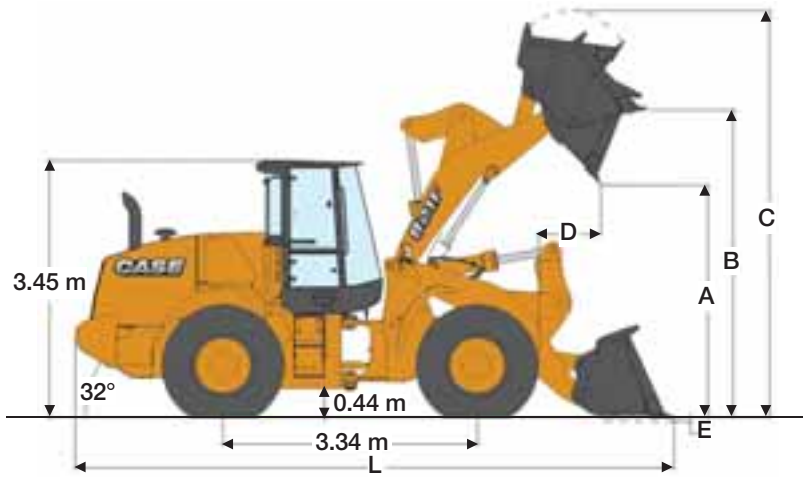

### LOADER SPEED

Raising time (loaded)	6.2 sec
Dump time (loaded)	1.2 sec
Lowering time (empty, power down)	2.9 sec
Lowering time (empty, float down)	2.5 sec

### 821F

Bucket with bolt on:		edge	teeth
Bucket volume (heaped)	m <sup>3</sup>	3.20	3.10
Bucket Payload	kg	6184	6295
Maximum material density	ton/m <sup>3</sup>	1.93	2.03
Bucket outside width	m	2.94	2.94
Bucket weight	kg	1520	1430
Tipping load - straight	kg	14284	14523
Tipping load - Articulated at 40°	kg	12367	12590
Breakout force	kg	15473	16676
Lift capacity from ground	kg	18055	18201
A Dump height at 45° at full height	m	2.96	2.88
B Hinge pin height	m	4.12	4.12
C Overall height	m	5.45	5.45
D Bucket reach at full height	m	1.15	1.27
E Dig depth	cm	7	5
L Overall length with bucket on the ground	m	7.90	8.03
Overall length without bucket	m	6.78	6.78
R Turning radius to front corner of the bucket	m	6.6	6.6
Bucket rollback in carry position	°	44°	44°
Dump angle at full height	°	55°	55°
Machine operating weight	kg	17664	17574

Note: Bucket specifications can differ slightly, please speak to your local Case Construction dealer for bucket options.

# THE DNA OF YOUR 921F

## PRODUCTIVITY (50-meter distance cycle)

Considering: density: 1,8 t/m<sup>3</sup>, fill factor: 100%, 52 cycles/hour and each hour includes a 5-minute break \_\_\_\_\_ 210 m<sup>3</sup>/h or 375 t/h  
52 loading cycles/h with standard bucket 4.0 m<sup>3</sup> or 7.2 ton

## ENGINE TIER 2

compliant with Tier 2 (EU stage II regulations)

FPT turbocharged engine F4HFA613D with:

- 100% fresh air combustion
- Air to Air intercooler
- Multiple injections similar to multi-jet automotive technology to achieve best in class load response, max torque and power with the minimum fuel consumption.

6 cylinders -6,7 liters

Max power SAE J1995 \_\_\_\_\_ 190kW / 255 hp @1800 rpm

Maximum torque SAE J1349 \_\_\_\_\_ 1300 Nm @1300 rpm

## TRANSMISSION

All-wheel drive with planetary axles

kick-down function

4-speed torque converter

4-speed auto Powershift switchable to manual shifting

ZF , switchable to manual shifting

forward speeds \_\_\_\_\_ 7-12-23-36 Km/h

reverse speeds \_\_\_\_\_ 7-13-24 Km/h

Adjustable transmission declutch

## AXLES AND DIFFERENTIAL

Front and rear ZF Heavy Duty axles with 100% front auto-lock differential.

(100% of available torque is always guaranteed on the front wheels)

Rear axle total oscillation \_\_\_\_\_ 24°

## TYRES

Tyres \_\_\_\_\_ 23. 5R25

## BRAKES

Service brake \_\_\_\_\_ Maintenance free,  
self-adjusting wet 4-wheel disc brakes

Area \_\_\_\_\_ 0.47 m<sup>2</sup>/hub

Parking brake \_\_\_\_\_ Disc brake on transmission  
activated from the cab cluster

Area \_\_\_\_\_ 82 cm<sup>2</sup>

## HYDRAULIC

Valves \_\_\_\_\_ Rexroth Closed-center, Load sensing hydraulic system.

Main valve with 3 sections

Steering \_\_\_\_\_ The steering orbitrol is hydraulically  
actuated with priority valve

Type of pump \_\_\_\_\_ Tandem Variable displacement pump  
(282 l/min @2000 rpm)

Automatic hydraulic functions

- Bucket Return-to-dig
- Boom Return-to-travel
- Auto.lift (to adjustableheight)

Control type \_\_\_\_\_ Pilot control with single joystick or two levers

## CAPACITIES

Fuel tank \_\_\_\_\_ 288 usable litres

Cooling system \_\_\_\_\_ 30 litres

Engine oil \_\_\_\_\_ 15 litres

Hydraulic oil \_\_\_\_\_ Tank: 110 litres, total system: 200 litres

Transmission oil \_\_\_\_\_ 34 litres

## CAB AND CONTROLS

For you safety the cab complies to:

protection against falling objects (FOPS) \_\_\_\_\_ ISO EN3449

protection against roll over (ROPS) \_\_\_\_\_ ISO EN13510

## NOISE AND VIBRATION

Driving noise in dB (A) 82 to SAE J88 @ 15 meters

Interior noise \_\_\_\_\_ 72 LpA as per ISO6595/6396/3744

Exterior noise \_\_\_\_\_ 71 dB(A) at 15 meters as per SAE J88 SEP80  
103 LwA according to ISO6395/6396/3744

Switchable reverse gear alarm

Vibrations \_\_\_\_\_ air-cushioned seat MSG 95A/732  
average 1.4m/s<sup>2</sup> as per ISO/TR 25398:2006

## ELECTRICAL SYSTEM

24V. Batteries 2 x 12V.

Alternator \_\_\_\_\_ 65A

# SPECIFICATIONS

## GENERAL DIMENSIONS

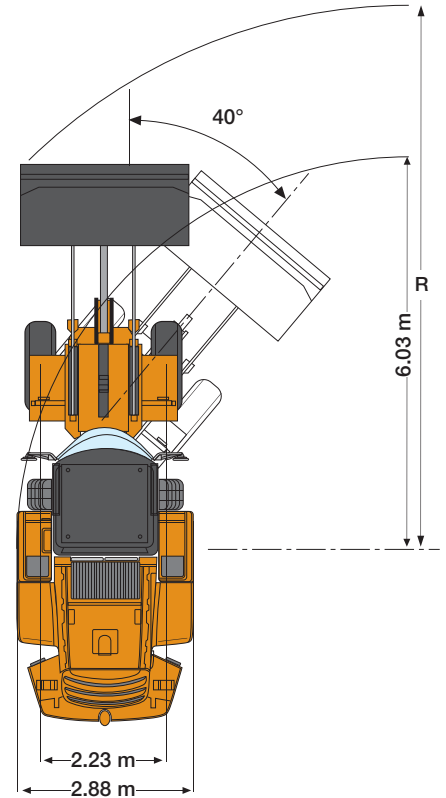
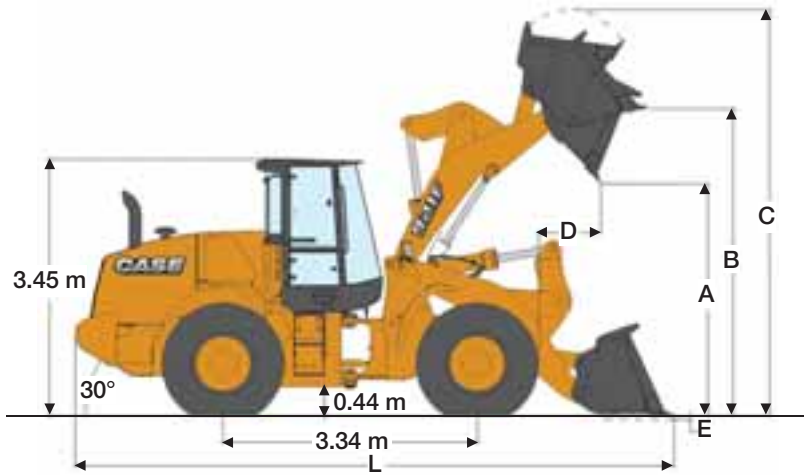

### LOADER SPEED

Raising time (loaded)	6.2 sec
Dump time (loaded)	1.4 sec
Lowering time (empty, power down)	3.8 sec
Lowering time (empty, float down)	3.1 sec

### 921F 3,6 m<sup>3</sup>

Bucket with bolt on:		edge	teeth
Bucket volume (heaped)	m <sup>3</sup>	3.20	3.10
Bucket Payload	kg	6184	6295
Maximum material density	ton/m <sup>3</sup>	1.93	2.03
Bucket outside width	m	2.94	2.94
Bucket weight	kg	1520	1430
Tipping load - straight	kg	14284	14523
Tipping load - Articulated at 40°	kg	12367	12590
Breakout force	kg	15473	16676
Lift capacity from ground	kg	18055	18201
A Dump height at 45° at full height	m	2.96	2.88
B Hinge pin height	m	4.12	4.12
C Overall height	m	5.45	5.45
D Bucket reach at full height	m	1.15	1.27
E Dig depth	cm	7	5
L Overall length with bucket on the ground	m	7.90	8.03
Overall length without bucket	m	6.78	6.78
R Turning radius to front corner of the bucket	m	6.6	6.6
Bucket rollback in carry position	°	44°	44°
Dump angle at full height	°	55°	55°
Machine operating weight	kg	17664	17574

Note: Bucket specifications can differ slightly, please speak to your local Case Construction dealer for bucket options.



www.casece.com  
**EXPERTS FOR THE REAL WORLD**  
**SINCE 1842**

**CASE**  
CONSTRUCTION



**CASE CONSTRUCTION EQUIPMENT**  
**CONTACT INFORMATION**  
**AUSTRALIA**  
**31-53 Kurrajong Road**  
**St. Marys nsw 2760**

**CASE** Customer Assistance  
**1300 99 CASE**

**NOTE:** CASE provides specific outfits for various countries and many optional fittings (OPT). The illustrations on this or other leaflets may relate to standard or optional fittings. Please consult your CASE dealer for any information in this regard and any possible updating on components. CNH Industrial reserves the right to modify machine specifications without incurring any obligation relating to such changes.

