

# S2255RT

## NARROW ROUGH TERRAIN SCISSOR LIFTS



- Narrow compact diesel rough terrain scissor lifts
- Excellent rough terrain performance
- Easy to operate
- Roll-out deck extension for extra reach
- Ideal for outdoor work in confined spaces

**snorkel**  
[www.snorkellifts.com](http://www.snorkellifts.com)

# NARROW ROUGH TERRAIN SCISSOR LIFTS

# S2255RT

DIMENSIONS	S2255RT
Max. working height	8.5m
Max. platform height (A)	6.5m
Platform size (stowed)	1.4m x 2.73m
Platform size (extended)	1.4m x 3.93m
Extension deck length	1.2m
Overall width (B)	1.45m
Overall length (C)	3.3m
Stowed height (D)	2.35m
Min. height (guardrails folded)	2.0m
Ground clearance	260mm

PERFORMANCE	
Platform capacity (SWL)	420kg
Max. drive height	6.5m
Max. wind speed	12.5m/s
Max. drive speed (stowed)	5.2km/h
Max. drive speed (elevated)	0.66km/h
Raise/lower time	26/30 sec
Gradeability	35%
Max. outrigger levelling, front to rear	6°
Max. outrigger levelling, side to side	10°
Inside turning radius	2.5m
Outside turning radius	4.75m
Exit/entry angle	20°
Tyres	23" x 8.9" - 12 non-marking
Controls	proportional joystick
Drive system	4 wheel drive

POWER	
Power source	Kubota diesel engine
Power options	bi-energy

WEIGHT	
Weight	2,410kg

## TURNING RADIUS

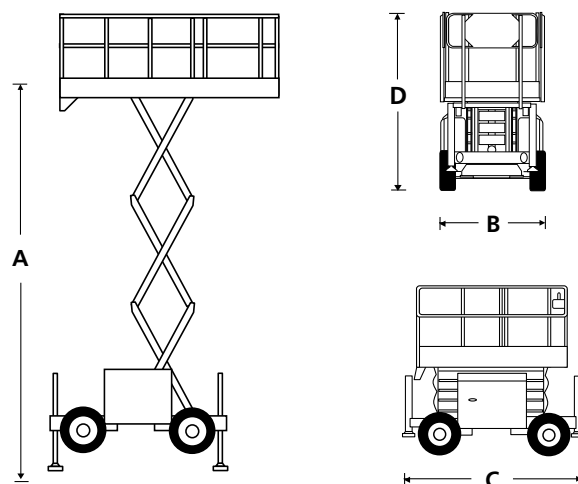
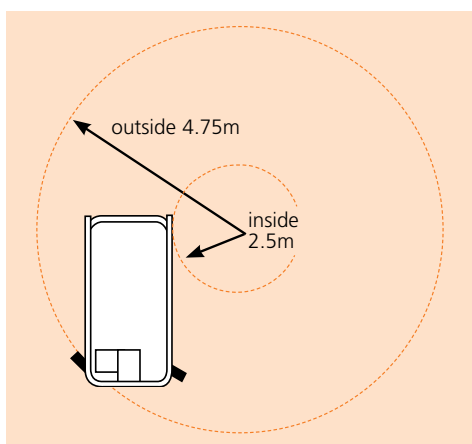

## STANDARD FEATURES

- 4 wheel drive
- 4 hydraulic outriggers with automatic levelling
- Roll-out deck extension
- Proportional controls
- Non-marking tyres
- Power line to platform
- Drive motion alarm
- Descent alarm
- Manual lowering valve
- Flashing amber light
- Dual lanyard attachment points
- Articulating axle
- Hour meter
- 2 year parts & labour, 5 year structural warranty
- CE approved

## OPTIONS

- Special paint colours
- Nylon spreader pads (set of 4)
- Environmental hydraulic oil

**snorkel** [www.snorkellifts.com](http://www.snorkellifts.com)

Vigo Centre, Birtley Road,  
Washington, Tyne & Wear,  
NE38 9DA, U.K.

t: +44 (0) 845 1550 057

e: sales.emea@snorkellifts.com